SENSIT[®] VMD

VEHICLE METHANE DETECTOR

SET-UP & OPERATING INSTRUCTION MANUAL

READ AND UNDERSTAND INSTRUCTIONS BEFORE USE.











SENSIT

851 Transport Drive • Valparaiso, IN 46383 (USA)
Phone: 219.465.2700 • www.GasLeakSensors.com

CONTENTS

FOR YOUR SAFETY	3
PARTS AND ACCESSORIES	4
PRODUCT AND TECHNOLOGY DESCRIPTION	5
MAINTENANCE	5
SPECIFICATION	6
SENSOR SPECIFICATIONS	6
PRODUCT SPECIFICATIONS	6
EXPLANATION OF PPM/M	7
INSTALLATION	8
INSTALL VMD INSTRUMENT	8
INSTALL TABLET COMPUTER	10
GETAC TABLET CONNECTIONS	11
USER INTERFACE	12
DESCRIPTION OF INTERFACE BUTTONS	13
USER SETUP TAB	15
OPERATION AND USE	16
CALIBRATION	17
ADVANCED CALIBRATION	18
PLOTTING SURVEYS	19
CONVERTING TO .KML AND EXPORTING	19
PAIRING A PMD	20
IMPORTING CALIBRATION DATA INTO SCAL	21
EXPORT DATA FROM TABLET TO REMOVABLE MEDIA	21
IMPORT DATA INTO SCAL	21
PAIRING BLUETOOTH CONNECTION	22
GETACT T800 TABLET	22
ADVANTECH TABLET	24
NOTES	25
WARRANTY	28

FOR YOUR SAFETY

-  **NOTICE:** This safety symbol is used to indicate a potentially hazardous situation which, if not avoided, may result in minor or moderate injury.
-  **WARNING:** Disassembly and maintenance is forbidden in explosive atmosphere.
-  **WARNING:** Follow the manual instructions and testing methods.
-  **WARNING:** Any disassembly or repair of the instrument must be done by a factory certified technician.
-  **WARNING:** Clean lenses prior to each use with a lint free or microfiber cloth for best results.
-  **WARNING:** When not in use refer to transport position recommendation to prevent potential damage.
-  **WARNING:** While the VMD is weather resistant, it is recommended to remove the instrument and store it in the vehicle when necessary to avoid prolonged exposure to extreme weather (i.e. heavy rain or snow).
-  **DANGER:** Use extreme caution when monitoring the tablet computer when driving. Rely on the audible alarm instead of any visual indication while driving. Any adjustment should be made only when the vehicle is safely stopped and away from traffic.

PARTS AND ACCESSORIES

STANDARD PARTS (INCLUDED)

360-00481	VMD Bluetooth antenna
360-00482	Tablet Bluetooth antenna
385-00159	Tablet Bluetooth antenna extension cable (right angle)
330-00097	Tablet Bluetooth antenna clamp
360-00471	Tablet GPS antenna
385-00114	VMD power harness assembly
385-00160	Tablet vehicle power supply
360-00586	Tablet dock
882-00092-SN	Calibration cell (with mounting arm & thumbscrew)
882-00137	Extra power harness cover
360-00430	5A automotive fuse for power harness

ACCESSORIES

870-00076	VMD shield
870-00105	VMD all-terrain shield

STANDARD MOUNTING KIT (VMD)

870-00052	Mounting kit (includes parts below)
330-00078	Hitch pins
360-00426	Jam bolt
360-00427	L-bracket
360-00428	VMD bar bracket
360-00429	Hitch stabilizer

ALL-TERRAIN MOUNTING KIT (VMD)

870-00106	All-terrain mounting kit (includes parts below)
330-00078	Hitch pins
360-00426	Jam bolt
360-00429	Hitch stabilizer
360-00580	VMD all-terrain bar bracket
360-00581	VMD all-terrain L bracket

MOUNTING KIT (TABLET)

870-00074	Mounting kit (includes parts below)
360-00473	Base w/ 2" Ball & Clamps
360-00474	Arm
360-00475	Plate (VESA 75)

PRODUCT AND TECHNOLOGY DESCRIPTION

The **SENSIT® VMD** is a vehicle-mounted natural gas leak survey instrument. It uses IR Absorption Spectroscopy technology for extremely accurate and consistent readings that are entirely methane specific. The **SENSIT® VMD** uses an open-path system, which consists of 2 modules that are mounted on a bar. One half emits a light source, which travels through the space between the modules into the other half which receives the signal. The amount of natural gas (methane) in the path affects how much of the light source is absorbed, which is translated into a parts-per-million-per-meter (ppm/m) reading.

The entire assembly is mounted to the front of a vehicle on a large L-bracket, which is received by a 2" hitch. The **SENSIT® VMD** is powered by a single cable coming from the battery of the vehicle, and can be removed easily to allow for very fast and simple removal and storage of the instrument. The data it gathers is sent via Bluetooth to a rugged tablet computer in the cab of the vehicle. The user is shown readings in real time (at a rate of one reading every 200ms), on a very easy to read graphical interface.

The **SENSIT® VMD**, in addition to using Bluetooth communication, also utilizes a built-in GPS module in the tablet. Combined with the software's logging capabilities, the user can map a survey directly into Google Earth, to see a detailed map of the survey with a breadcrumb trail of the path driven and readings found.

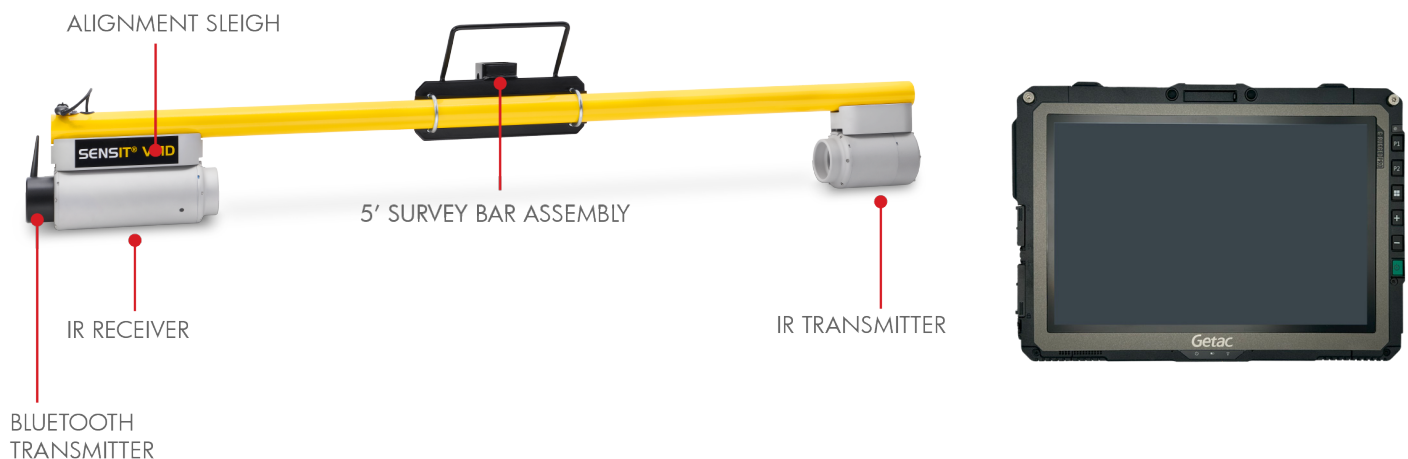

MAINTENANCE

- | Be sure to check all fasteners to ensure they are tight and not damaged/corroded at the beginning of the day and periodically throughout the day
- | Keep anti-seize on all jam bolts
- | Keep di-electric grease on the VMD power harness electrical connections, power harness should never be left open to the elements when VMD is not in use, a cover is provided for this purpose
- | Wipe lenses with a non-abrasive cloth before each day's use or when a "low light" alarm cannot be cleared, if needed, use a "lens cleaner" solution

SPECIFICATION

SENSOR SPECIFICATIONS

Sensitivity:	0.1 ppm/meter methane at a max speed of 25mph
Measurement Range:	1.0 to 1000 ppm/meter
Display Range:	Automatic
Accuracy:	±10%
Alarms:	Audible with adjustable set point

PRODUCT SPECIFICATIONS

System Voltage:	10-16 VDC
System Power Requirements:	84 watts max @ 12 VDC
VMD Size:	4 ft. to 8 ft. path length (5 ft. Standard)
Tablet Weight:	1.94lbs (0.88kg)
Tablet Size:	8.93" x 5.94" x 0.94" (227 x 151 x 24mm)
VMD Weather Resistance:	IP54
Tablet Weather Resistance:	IP65
Operating Temperature Range:	-20°F to 122°F
Operating Humidity Range:	5 to 100% relative humidity
Installation Time:	< 2 hours (typical)

EXPLANATION OF PPM/M

The **SENSIT® VMD** displays its readings in parts per million per meter. This is a representation of the average gas concentration over 1 meter, or roughly 3.3 feet. Many types of IR and laser based technology in the industry uses this standard. For implementations that are not fixed point, and have a variable path length, the unit used is ppmm (parts per million meter). The difference being that the reading would be a factor of the total distance of the path length, which can change as the size of the gas plume changes.

In the case of the **VMD**, the path length is fixed at slightly more than 1m, which is taken into account in the software, and we therefore say the reading is “per meter”, meaning over the total length, since it never changes.



However, this reading is still essentially an average. For example, consider the following images:



On the left, there is a natural gas plume with a concentration of 40ppm, spanning 0.5m. On the right, there is a plume with a concentration of 80ppm, spanning 0.25m. Both of these scenarios will yield the same reading of **20ppm/m**. The plume on the right is double the concentration, but half the distance, meaning the average concentration over the path length will remain the same.

INSTALLATION

INSTALL VMD INSTRUMENT

1. Install a 2" front-mount hitch on the front of the vehicle. If a bolt on hitch cannot be sourced, a local welding shop should be able to mount one for you as pictured below.



2. Insert the short end of the L-bracket into the hitch with the long side facing up. There are several adjustment holes for distance in and out from the bumper. Insert the pin and install and tighten the hitch stabilizer. The hitch stabilizer tightens the L-bracket to the hitch, and therefore the frame of the vehicle. This ensures that no extra vibrations are transferred to the **VMD**.



3. Ensure that the jam bolt is backed out from the bracket that is mounted to the **VMD**. Slide the **VMD** and mounting bracket over the L-bracket, lower the **VMD** to the desired position, and insert the pin. Tighten the jam bolt. It is recommended to use an anti-seize compound on the jam bolt.

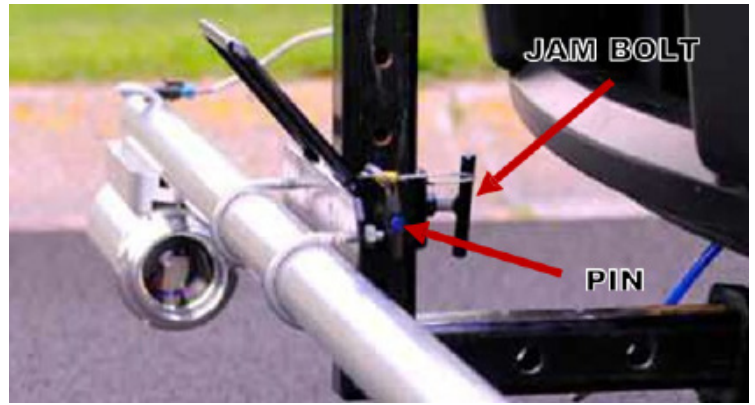

4. Install the power harness assembly.
- a. Route the power harness through the grill and engine compartment to the battery. The harness is 10ft long and should have some slack left over.
 - b. The battery end of the power harness has two exposed wires, **red** for the positive terminal of the battery and **black** for negative. Secure these wires to the battery. One method is to use crimp-on ring terminals that can then be bolted to the battery terminals.
 - c. Plug in the power connector to the **VMD**.
 - d. It is recommended to use dielectric grease on all connections to prevent corrosion.

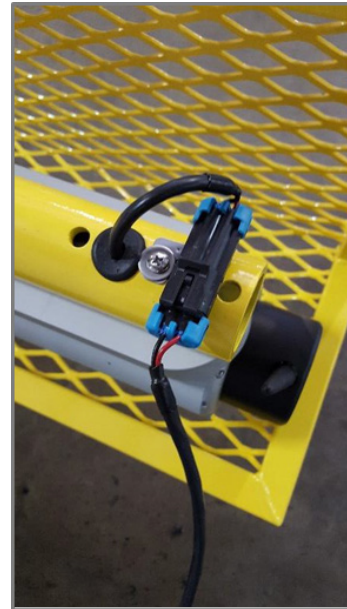

INSTALL TABLET COMPUTER

There are various methods for mounting the tablet computer. There is not a universal mounting system that will fit all vehicles, and therefore Sensit does not provide a full tablet mounting solution. What is provided is a ball-joint bracket and mounting arm. The ball-joint and mounting arm can be attached to the back of the tablet with the provided hardware. The arm can then be secured to a pole that is mounted in the cab of the vehicle (not provided). On an ATV or utility vehicle application, there will usually be a roll bar or other similar structure that the arm can be attached to.

Alternatively, after market computer/tablet mounts are available from a variety of vendors. Most commonly, these will use an arm or adjustable pole that will bolt to the front-passenger seat mounting points. This can either be the full solution (which will mount to the tablet) or can sometimes be used in conjunction with the provided ball-joint and arm.

If you need assistance with this, contact **SENSIT Technologies**.

GETAC TABLET CONNECTIONS

The provided tablet for the **SENSIT® VMD** is the Getac UX10. Also provided is a dock for the tablet, which has pass-through connections for the Bluetooth and GPS signals. The antennas for each is attached to SMA connectors on the bottom of the dock. The Bluetooth antenna (8") will most likely be pre-installed. The GPS antenna has a magnetic puck with 10 feet of cable and will need to be installed by the user.

Refer to the picture below for a description of each connection. Also shown is the provided mounting arm.

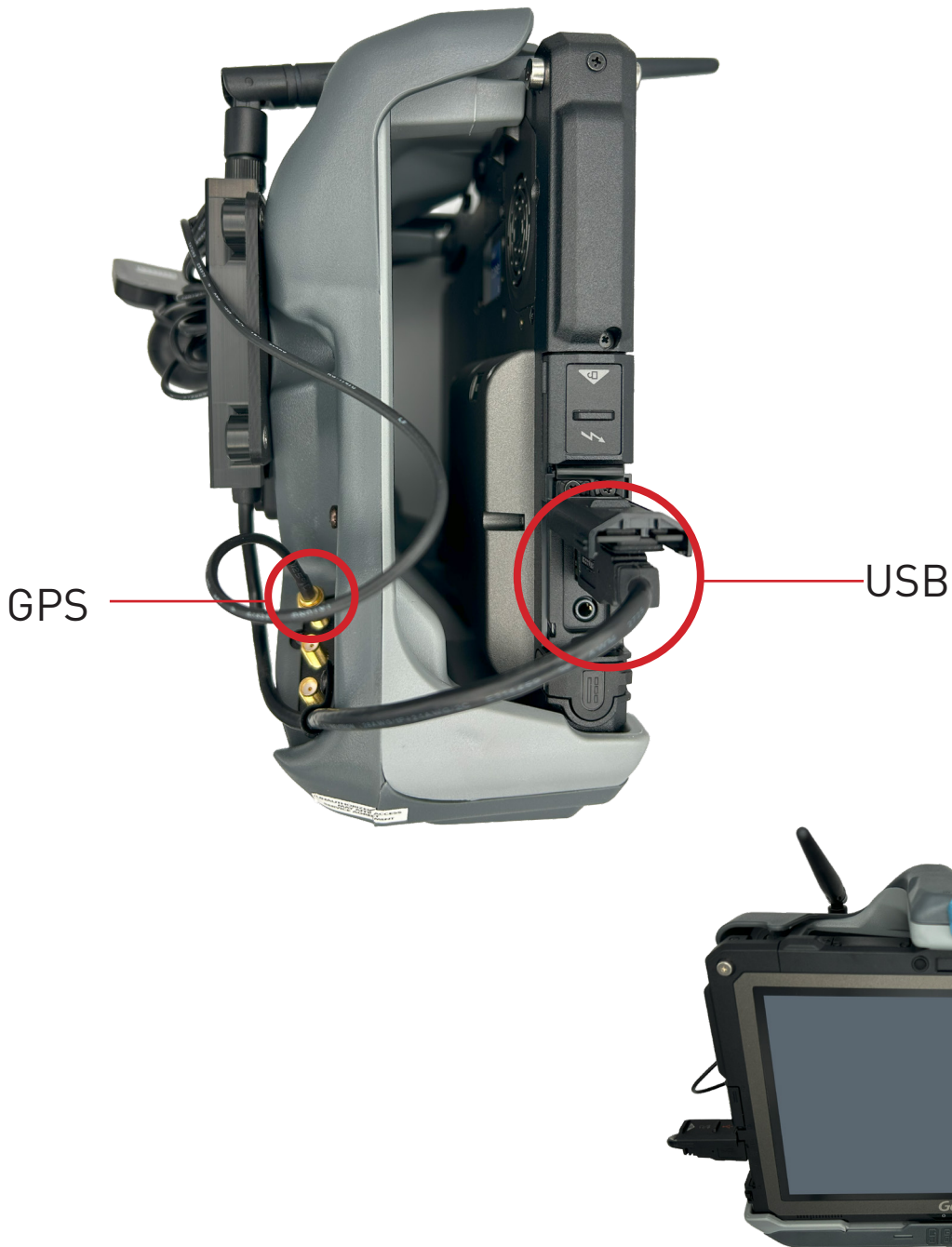

USER INTERFACE

The user interface of the **SENSIT® VMD** is controlled by a tablet computer with a touch screen. The instrument streams all data over Bluetooth to the tablet, where it is displayed in real time (200ms sample time).

The majority of the screen is reserved for survey data to be displayed. The bottom and left parts of the screen have command buttons that can be used as needed. The top part of the screen has tabs for various display modes and menus.

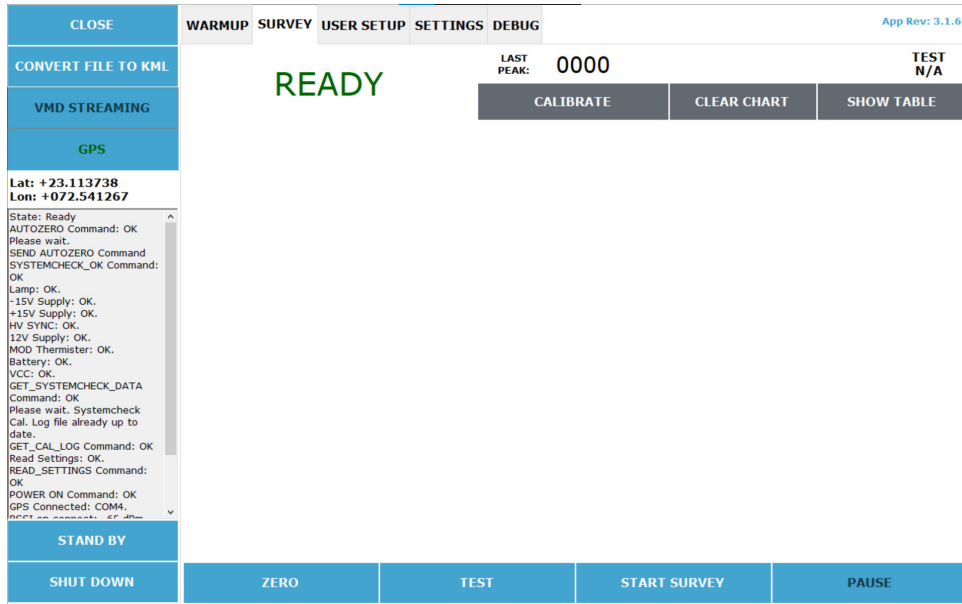

Refer to the image below and descriptions on the next page for how each of these buttons are used.

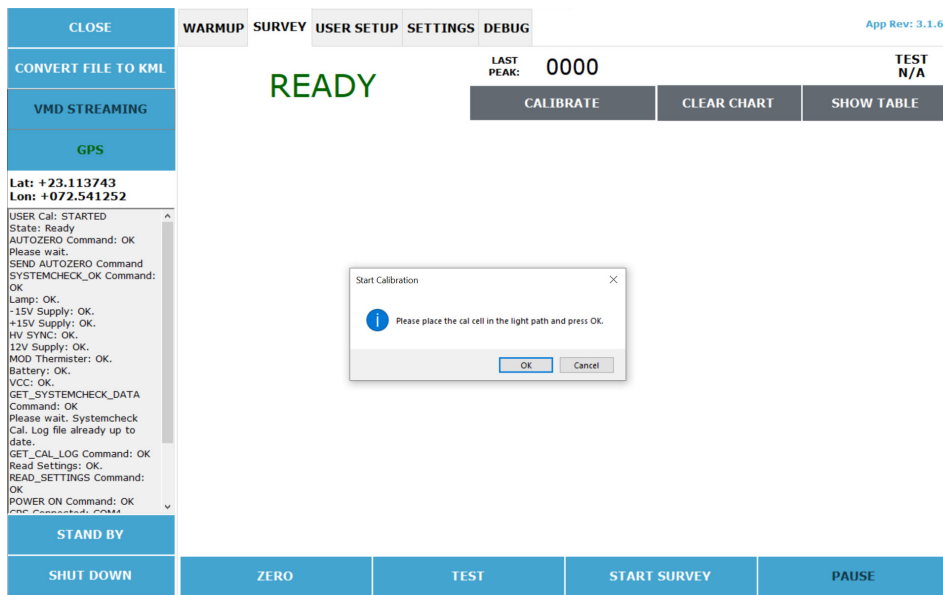

DESCRIPTION OF INTERFACE BUTTONS

Main Function Buttons (bottom of screen):

1. POWER ON / SHUT DOWN

Shuts off the **VMD**. Does not close the application or shut off the tablet.

2. ZERO

Sets a new zero baseline for the current survey (or next survey). Does not alter the calibration or sensitivity of the instrument.

3. TEST

Performs a self-test function of the instrument. A cell with a known concentration of gas inside the instrument is inserted into the detecting path. The **VMD** detects this gas and shows the operator a reading, as well as a test **pass/fail** indication.

4. START/STOP_SURVEY

Starts or stops a survey. No readings will be displayed or recorded if a survey isn't running. The user will be prompted when starting a survey to either save data to the previous log file or start a new one (unless logging is disabled). Survey must be stopped to calibrate the instrument.

5. PAUSE/RESUME

Pauses and resumes the survey instead of starting and stopping. This will assume the user wants to continue with the previous log file. Also used to resume the survey if it gets interrupted due to low light.

Function Button (left side of screen)

1. CLOSE

Closes the application but does not shut off the **VMD**. This allows the user to bypass the warm-up period if the application is opened again. When used, a time-out period of 10 minutes begins, after which the **VMD** will be powered off. This is useful if the user needs to access some other part of the operating system, but wants to resume surveying afterwards.

2. CONVERT FILE TO KML

Menu for converting a datalog file to '.kml' file format instead of '.csv'. '.kml' files are used for viewing data with a mapping/GIS application, such as Google Earth. GPS data is required in order for a file to be converted.

3. VMD/PMD STREAMING

Status/indication icon for state of any streaming options that are enabled.

4. GPS

Status/indication for GPS functionality.

If no GPS signal is detected, the GPS label will appear in **red** and the white box below will display 'GPS not found'. If a GPS signal is detected but the device has not yet determined its location (latitude and longitude), the GPS label will appear in **grey** and the white box below will display 'Acquiring Fix'. If GPS signal is available and its location has been determined, the GPS label will appear in **green**, and the coordinates will be displayed below.

5. STAND BY

Puts the instrument in a low power state. User must wait 120 seconds before use when it is woken up.

Display Modes/ Menu Tabs (top of screen):

1. **NORMAL/WARM-UP**

Initial startup and warm-up screen. Only shown after first power on and while the instrument is warming up. Outputs basic sensor information. The user does not need to interact with the instrument during this process.

2. **SURVEY**

Main operation mode for use of the instrument. From this mode the user can start and stop surveys, use the self-test function, calibrate the instrument, etc. For more information, see the sections on operation and calibration.

3. **USER SETUP**

Contains settings and configuration options that are available to the user at any time. Alarm settings, calibration logs, Bluetooth streaming, etc. For more information, see the following section.

4. **SETTINGS**

Password protected settings menu that contains factory level adjustments.

5. **DEBUG**

Password protected menu that outputs debug information. Only used for troubleshooting purposes.

Other Buttons (upper right of screen)

1. **CALIBRATE**

Starts the calibration process. The user will be prompted to place the calibration cell on the instrument. Calibration takes less than a minute. See the calibration section for more information.

2. **CLEAR CHART**

Clears the current information on the screen. This is only visual and does not restart the survey or remove any data from the log.

3. **SHOW TABLE/SHOW GRAPH**

Switches between displaying survey information with a graph and with a table. The graph (default) has a visual representation of the readings in the form of a timeline, and is generally preferred.

USER SETUP TAB

The user setup tab contains settings and configuration options that are available to the user at any time, as well as calibration information. It is accessed by selecting the user setup tab from the top of the screen. The survey must be stopped in order to access it.

#	DATE TIME	RESULT	CAL PPM	CAL M	CAL L	ZERO M	ZERO L	OPT TEMP
1	06 Dec 2017 10:20:59	SKIPPED	102	30623	44775	32440	53373	2136
2	18 Jul 2017 07:43:37	PASSED	102	30623	44775	32521	50906	2136
3	22 May 2017 08:30:57	PASSED	102	30508	46416	32554	49875	2151
4	17 Apr 2017 06:41:36	PASSED	102	30314	47173	32507	53043	2166
5	13 Apr 2017 14:38:04	PASSED	102	30433	47921	32603	54084	2166

From this menu, the user can:

- Change the graph settings for time displayed on the X axis (default 120 seconds) and PPM range displayed on the Y axis (default 0).
 - For the PPM setting, 0 means that there is no limit and the display will auto-range. Using another value will fix the Y axis to that value and it will not adjust.
- Change the alarm set point (default 10).
- Change the Calibration Interval (default 90 days).
- Setup Bluetooth streaming and/or PMD Bluetooth settings
- View and export calibration data

Description of Blue Labels

- **SR#:** Serial number of the connected device.
- **App Rev:** Application revision number
- **VMD Rev:** Revision number of the firmware loaded on the connected VMD device.
NOTE: BL Rev (Bootloader Revision Number) will be displayed along with VMD Rev if it is present on the device.
- **Hardware Rev:** Revision number of the connected VMD hardware/board.

OPERATION AND USE

 **WARNING:** Always start any **SENSIT® VMD** in a gas free environment to ensure a proper zero.

1. Activate the computer by pressing the green power button located on the lower right hand side of the tablet. The system will boot up.
 - a. If the **VMD** application does not automatically begin, double click the icon on the desktop screen.
2. Click power on to begin the warm-up process, which will take approximately 7-10 minutes.
 - a. The graph and chart on the screen will show various diagnostic information during the warm-up process, such as the light level, sensor output, and internal temperature. This information is only pertinent for troubleshooting purposes.
3. After the **WARM UP** and **AUTOZERO** complete, the display will show ready in the survey mode. **READY** should be displayed in the upper left of the screen.
 - a. If the **AUTOZERO** failed, **ZERO FAIL** will be displayed. Please check that nothing is obstructing the light path and that there is no dirt or other debris on the lenses. Try manually performing a zero by pressing the **ZERO BUTTON**.
4. Travel to the area where the survey will begin.
5. If necessary, lower the **VMD** from the transport position (higher on the L-bracket) to the survey position (lower on the L- bracket). The L-bracket allows for a broad range of height adjustment. Adjust as needed and tighten the jam bolt. In general, the survey position should be as low as possible on the L-bracket without any potential of collision.
6. Use the **TEST BUTTON** to do a self-test of the instrument.
 - a. A test can be performed at any time during a survey as well. It will be logged along with your survey as test data (appears differently than survey data).
 - b. A **TEST PASS** or **TEST FAIL** message will be displayed in the upper right of the display after the test has completed.
 - c. If the test fails, perform a calibration. A failed test pauses the survey. You can restart the survey by using the **RESTART BUTTON**.
7. Press the start **SURVEY BUTTON** to begin the survey.
 - a. The user will be prompted to choose to add onto the previous log file or being a new log file. This is useful if one survey or route has to be completed over multiple sessions.
 - b. Live readings will appear on the screen. By default this is shown as a graph, but can be displayed as a table if desired.
 - c. If readings exceed the alarm point (10ppm/m default), an audible and visual alarm will be triggered.
 - d. If at any time the light path is obstructed, the survey will stop and low light will be displayed along with an audible tone and warning message. Check for obstructions in the light path or any dirt or other debris on the lenses. Try to manually zero the instrument by pressing the **ZERO BUTTON**.
8. Press the **STOP OR PAUSE** buttons as necessary to stop or pause the survey.

CALIBRATION

WARNING: Calibration must be performed in a gas-free environment. Calibration cycles over 90 days are not recommended. Using calibration kits other than recommended by **SENSIT Technologies** may cause inaccurate readings. Repairs are required if the instrument fails to calibrate. Consult the factory for details.

The **SENSIT® VMD** is calibrated with an external calibration cell assembly, which contains a known concentration of gas trapped between two plates of glass. Unlike calibrating a conventional CGI, this calibration process does not use a consumable. By default, the calibration cycle of the **SENSIT® VMD** is 30 days, but can be increased or decreased to match your company policies. There is no harm in performing a calibration process as often as desired (even daily).

1. Power on the instrument and wait for the warm-up process to complete.
 - a. If the instrument is already powered on, calibration cannot be done while a survey is running. The survey must be **STOPPED** and not **PAUSED**.
2. Hang the calibration cell on the bar of the **VMD**, so that the light will pass through it, up against the housing of either module. Tighten the thumbscrew.
3. On the tablet, select the calibrate button. A dialog box will appear asking you to place the calibration cell on the bar. Select **OK**. The calibration process will begin.

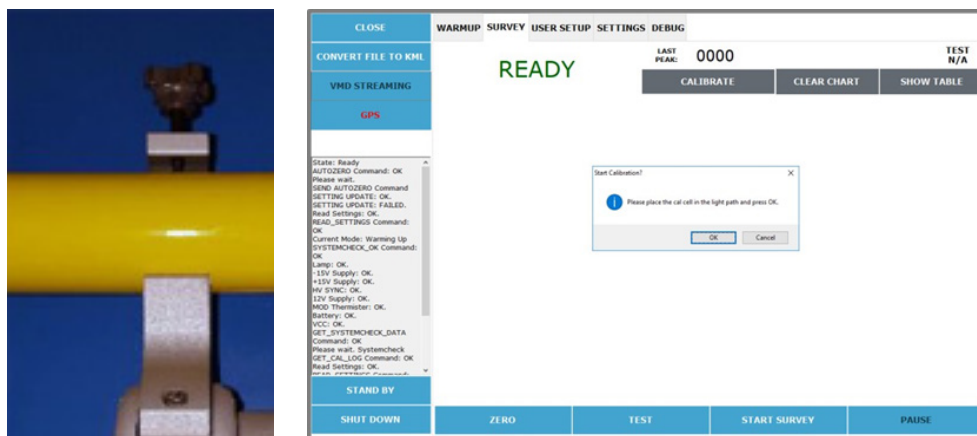

4. In the upper left of the screen, the current reading will be displayed as it is adjusted during calibration. This should be very close to 100ppm/m. Once calibration is successful, **READY** will be displayed.
 - a. If calibration failed, **CAL FAIL** will be displayed. Attempt calibration again. If calibration continues to fail, contact Sensit Technologies Service Department for assistance.

NOTE: In certain scenarios, if calibration fails, the instrument may need to have an advanced calibration performed. In this case, the user will be prompted to do so with a dialog box after a failed calibration.

ADVANCED CALIBRATION

WARNING: Calibration must be performed in a gas-free environment. Calibration cycles over 90 days are not recommended. Using calibration kits other than recommended by **SENSIT Technologies** may cause inaccurate readings. Repairs are required if the instrument fails to calibrate. Consult the factory for details.

Beginning with software revision 3.10(app)/3.02(firmware), advanced calibration is automatically be performed instead of the normal calibration on a 90 day cycle. This process is described below.

1. After the calibration has started, the display will change to the Advanced Calibration screen. This process will take between 2-5 minutes to complete.
2. When the Advanced Calibration is done, the display will return to the survey screen.
3. A “PLEASE WAIT...” message will be displayed. The user will be asked to remove the calibration cell so that a factory zero can be automatically performed. Press “OK” after the cell has been removed.
4. The “PLEASE WAIT...” message will continue to display for a few seconds. Afterwards, the calibration will be complete.

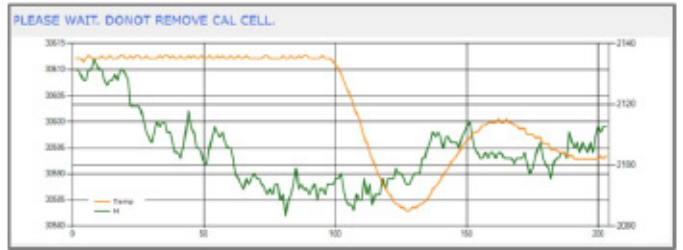

- a. If calibration is successful, **READY** will be displayed.
- b. If calibration failed, **CAL FAIL** will be displayed. Attempt calibration again. If calibration continues to fail, contact Sensit Technologies Service Department for assistance.

PLOTTING SURVEYS

The **SENSIT® VMD** saves a data log file for every survey conducted. These files will contain the date, time, ppm/m reading, and GPS coordinates if available. With valid GPS coordinates, these files can be converted to .kml format and viewed with mapping software. This gives a breadcrumb trail for the route driven with the vehicle, including any readings found above the chosen alarm points and any self-tests performed.

This section details how to convert these files, export them, and view them in Google Earth.

CONVERTING TO .KML AND EXPORTING

1. Power on the tablet computer. Allow it to fully boot and load the VMD application.
2. From the VMD application, select the CONVERT FILE TO KML from the upper left of the screen. The VMD does not have to be powered on.
3. On the following screen, select SELECT FILE TO CONVERT. A file select window will appear.
4. Navigate to the location datalog file(s) that you want to convert. By default, the VMD will save log files to the desktop.
5. Select one or more files and hit OPEN. You will be returned to the previous screen.
6. Make any adjustments necessary to the pin assignments. Anything below the value chosen for the yellow pin will not be shown on the map.
7. If you are planning to export right away to a flash drive, insert the drive now.
 - a. The USB port is on the right side of the tablet. Access it by pushing down the cover and lifting up.
8. Select CONVERT. A save window will appear.
 - a. If you get an error message, this means that one or more files you have chosen did not have valid GPS coordinates. Any valid files in the selection can still be converted.
9. Navigate to the location that you would like to save the files to. If you are exporting to a flash drive, select the drive from the list on the left.
10. Select save. A message will appear confirming that you have successfully created .kml file(s).
11. The .kml files can be opened directly into Google Earth to view the data.



PAIRING A PMD

The **SENSIT® VMD** and **PMD** have the ability to be used as a paired system. In this case, the **PMD** will be used in conjunction with a vacuum system, with cones on the front of the vehicle being drawn from with the aid of a powerful external pump. Readings from the **PMD** can be streamed real time using Bluetooth to the **VMD** tablet, so that the user has information from both instruments at the same time.

Additionally, this information can be logged, along with the GPS coordinates from both instruments, which can then be mapped with Google Earth. This is especially advantageous for use cases where the vehicle will be stopped when a reading is found, and the leak will be pinpointed using the **PMD**. That way, the path of the vehicle is shown as well as where the walking survey was conducted to find the leak.

When ordered as a system, the **SENSIT® VMD** and **PMD** will be shipped already paired from the factory. If for some reason this needs to be done in the field, contact **SENSIT Technologies** for assistance.

IMPORTING CALIBRATION DATA INTO SCAL

Calibration data from the **SENSIT® VMD** can be imported into **SCAL-D** or **SCAL-N** data management software. This data will then be incorporated into the database and can appear on reports with all other instruments in the system. If you are unfamiliar with **SCAL** and would like more information, contact **SENSIT Technologies**.

EXPORT DATA FROM TABLET TO REMOVABLE MEDIA

1. Power on the **SENSIT® VMD** tablet and allow it to fully boot.
2. Insert some removable media (such as a flash drive) into one of the USB slots of the tablet.
3. After the **VMD** application has loaded, hit the close button in the upper left of the screen.
4. On the desktop, find the folder labeled 'Calibration_Log'.
 - a. This is the default location. If this has been changed in the 'User Setup' menu, navigate to that location.
5. Select the folder so that it is highlighted, and then select and hold the folder until a sub-menu appears.
6. Select 'Send To' from this menu, and then your removable drive. The folder will be copied onto the drive.



GETAC T800



GETAC UX10

IMPORT DATA INTO SCAL

1. Insert the removable media into the machine with SCAL-N / SCAL-D installed.
2. Open SCAL-N / SCAL-D.
3. Select the 'File' menu, followed by the 'Import' option.
4. A window will appear. Navigate to the location of the calibration data (on the removable media).
5. Select the appropriate data file and hit 'Open'.

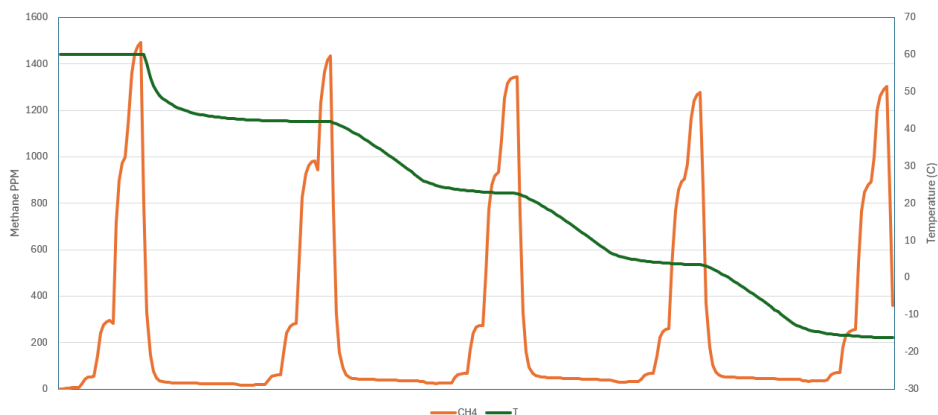

PAIRING BLUETOOTH CONNECTION

The **SENSIT® VMD** tablet and instrument are paired together via a Bluetooth connection. This is done at the factory, but if the need ever arises to re-pair this connection (or establish a new one), follow these steps, depending on the model of tablet you have. ***T800 Uses Windows 10 & UX10 Uses Windows 11**

GETAC UX10 TABLET

1. Close the VMD application by hitting the CLOSE button in the upper left of the screen.
2. Select the Bluetooth icon in the system tray in the lower right of the screen. A menu should appear.
3. From the menu, select SHOW BLUETOOTH DEVICES. A window should appear.
4. If there is a VMD instrument currently paired, select it. It should be named "VMDxxxx", where "xxxx" is the serial number of the instrument.
5. Select REMOVE DEVICE. After a few seconds, the device should no longer be shown as paired.
6. Select the VMD that needs to be paired and select PAIR. After a few seconds, the device should show "Connected", followed by "Paired".

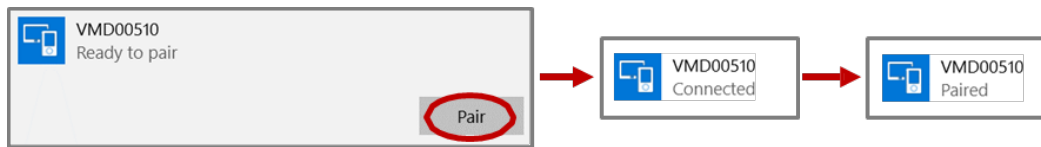
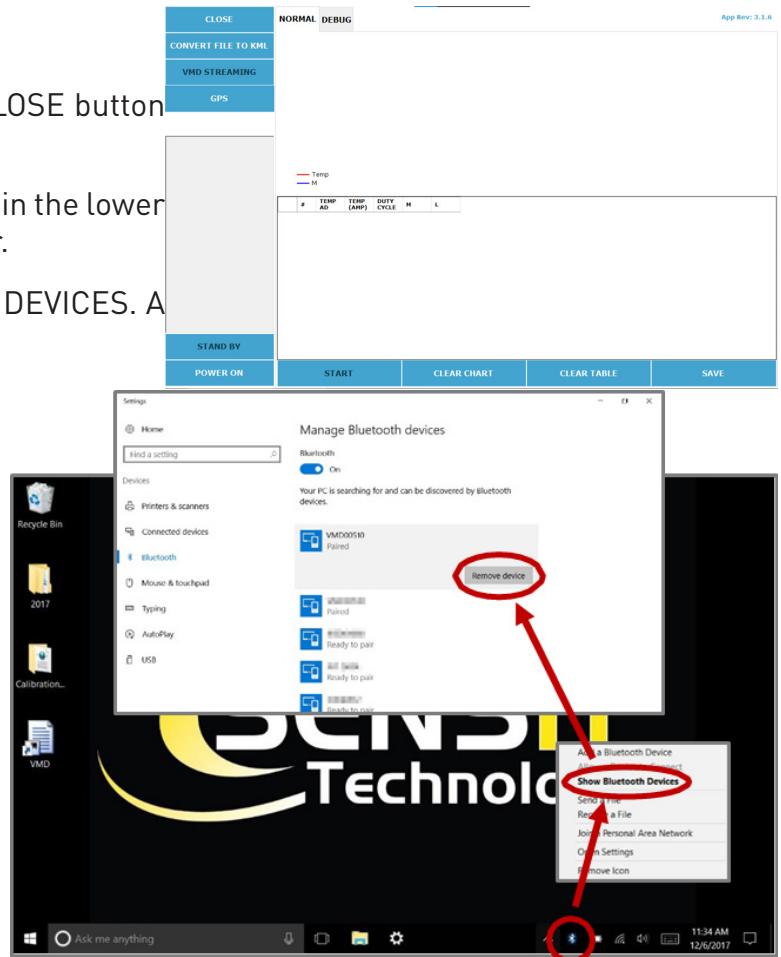

7. Close the Bluetooth window.
8. Double click the VMD icon on the desktop to restart the application.
9. Select the POWER ON button. The VMD should connect and the warm-up process should begin.
 - a. If you still receive a connection error, contact Sensit Technologies for assistance.

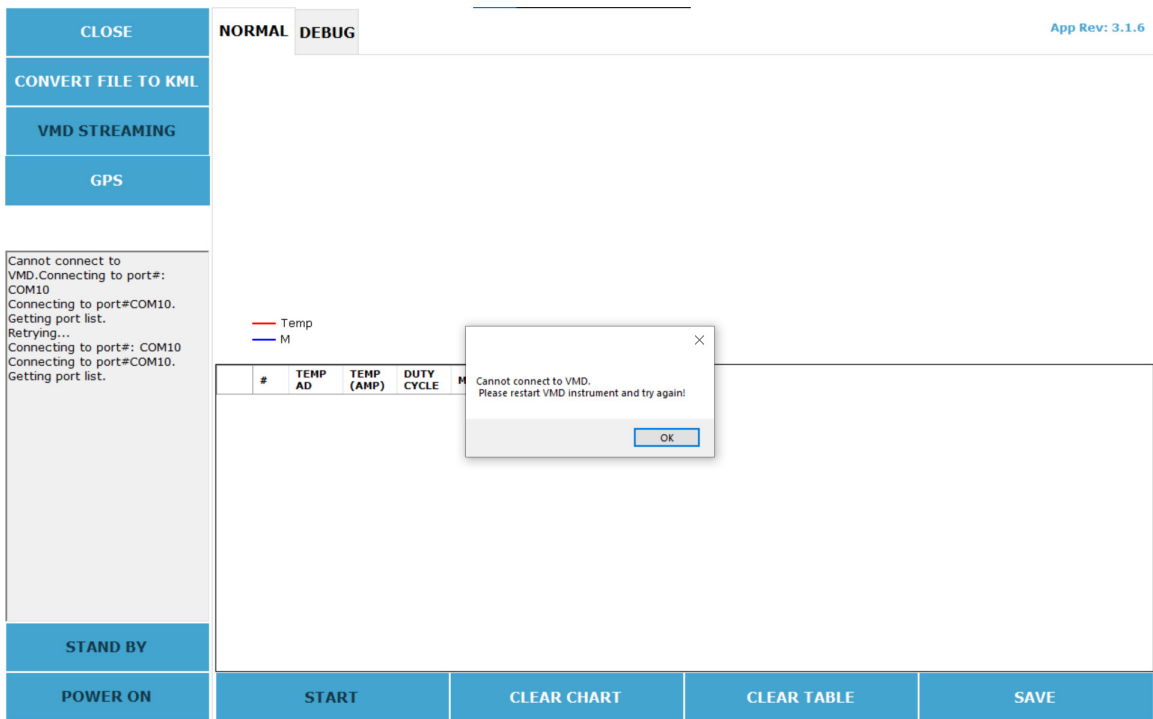
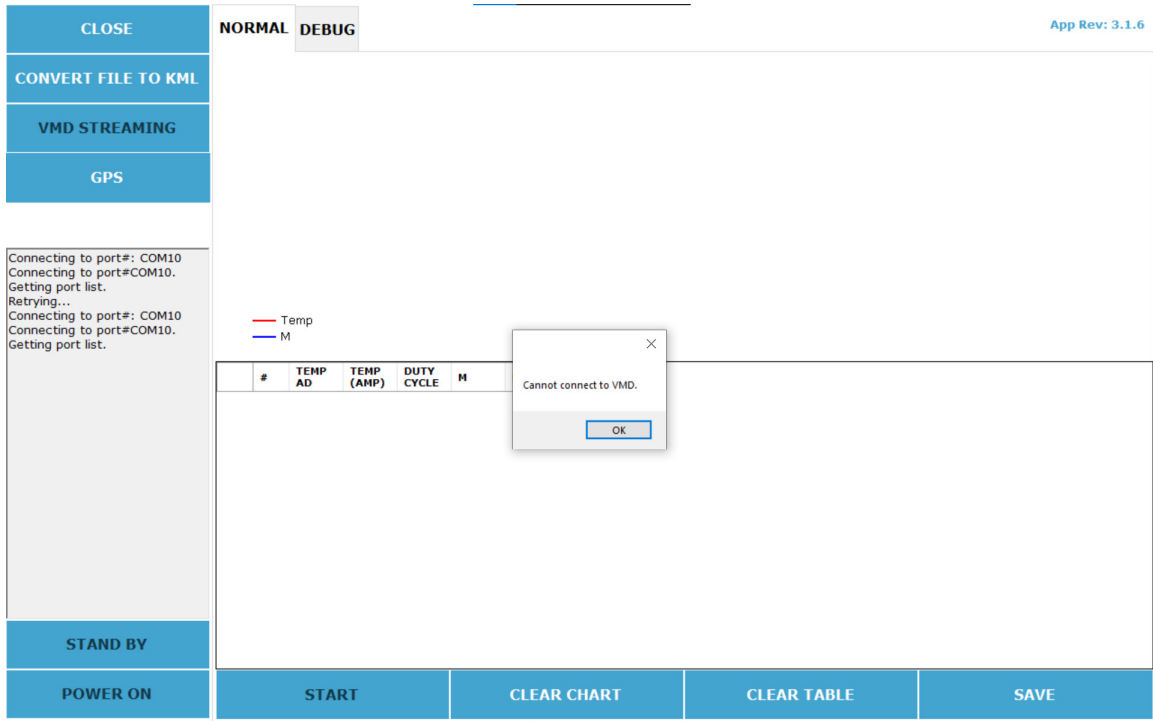

WARRANTY

Your **SENSIT VMD**[®] is warranted to be free from defects in materials and workmanship for a period of two years after purchase (excluding calibration and batteries). If within the warranty period, your instrument should become inoperative from such defects, the unit will be repaired or replaced at our option.

This warranty covers normal use and does not cover damage which occurs in shipment or failure which results from alteration, tampering, accident, misuse, abuse, neglect or improper maintenance. Proof of purchase may be required before warranty is rendered. Units out of warranty will be repaired for a service charge. Internal repair or maintenance must be completed by a **SENSIT Technologies** authorized technician. Violation will void warranty. Units must be returned postpaid, insured and to the attention of the Service Dept. for warranty or repair. This warranty gives you specific legal rights and you may have other rights which vary from state to state.

851 Transport Drive
Valparaiso, IN 46383-8432, USA
Phone: 219.465.2700
Toll Free: 888.4.SENSIT (473.6748)
Fax: 219.465.2701
Email: info@gasleaksensors.com
Website: www.GasLeakSensors.com

MADE IN THE USA
WITH GLOBALLY SOURCED COMPONENTS

The logo for SENSIT, with the word "SENSIT" in a bold, black, sans-serif font. The letters "I" and "T" are highlighted in a bright yellow color.